

DUCTLESS MINI SPLIT SYSTEM AIR CONDITIONER / HEAT PUMP



WAS / WYS Series

WAS: Cooling Only Version

WYS: Cooling and Heating Version

Inverter+[®] and Inverter++[®] Models

For 9,000-36,000 BTU/hr Systems

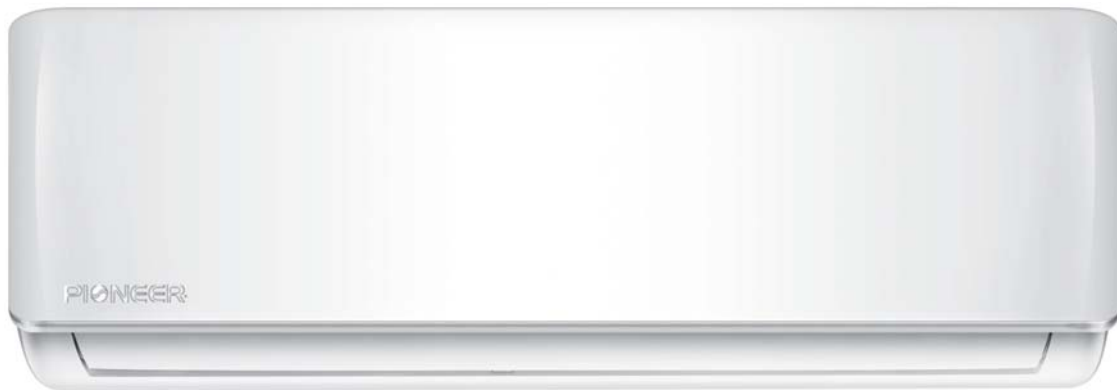

Owner's Manual

IMPORTANT NOTICE:

Please read this manual carefully before installing or operating your new air conditioning system. Be sure to save this manual for future reference.



Table of Contents

Owner's Manual

0 Safety Precautions.....04

1 Unit Specifications and Features.....06



3 Care and Maintenance.....12

4 Troubleshooting.....14

5 European Disposal Guidelines.....18

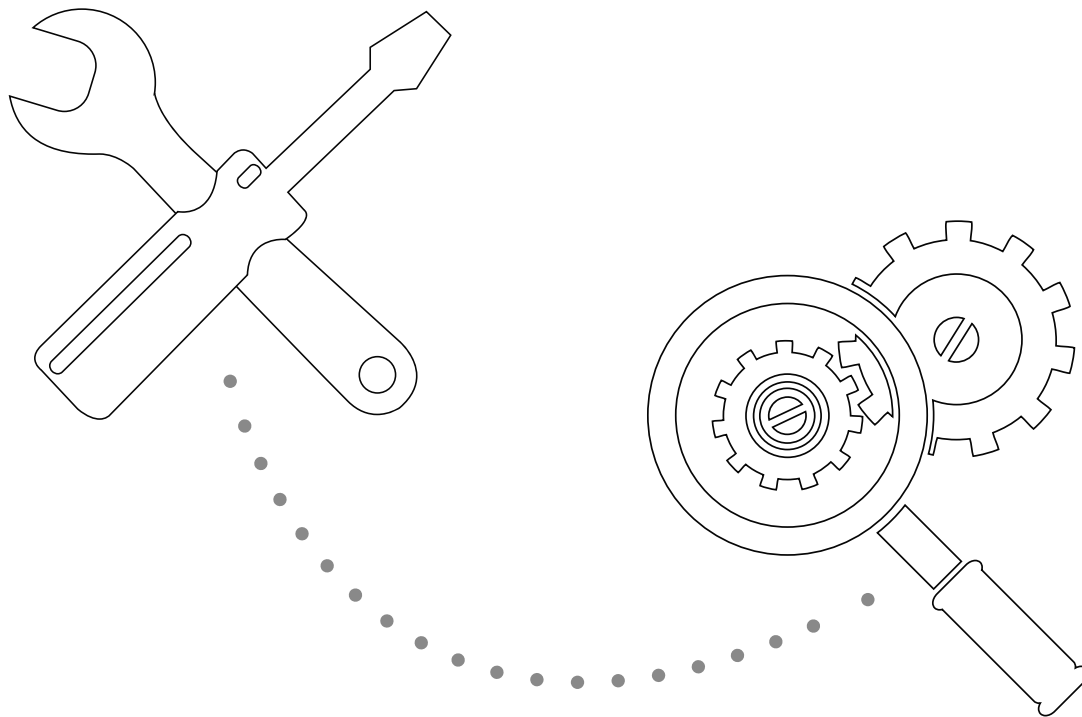

Safety Precautions

Read and Understand Safety Precautions Prior to Installation

Improper installation due to negligence of instructions may result in serious damage or injury. The magnitude of potential damages or injuries is classified as either a WARNING or a CAUTION.



WARNING

This symbol indicates that ignoring the related instructions may cause death, or serious injury.



CAUTION

This symbol indicates that ignoring the related instructions may cause moderate injury to nearby persons, and/or damage to your appliance or other property.



WARNING

This appliance can be used by children aged from 8 years and above, as well as persons with reduced physical, sensory, or mental capabilities, or lack of experience or knowledge, if they have been given supervision or instruction concerning use of the appliance in a safe way, and understand the hazards involved. Children shall not play with or near the appliance. Cleaning and user maintenance shall not be done or attempted by children or untrained personnel without proper supervision.

INSTALLATION WARNINGS

- Ask a licensed HVAC contractor to install this air conditioner. Inappropriate installation may cause condensate water or refrigerant leakage, undesired performance, electric shock, and/or fire.
- All repairs, maintenance, and relocation of this unit must be performed by a properly trained service technician. Improper repairs may lead to serious injury and/or product failure.

WARNINGS FOR PRODUCT USE

- If any abnormal situation arises (e.g. burn odors), immediately turn off the unit and shut off the circuit breaker. Call your installer for instructions on avoiding electrical shock, fire, and other injuries.
- Do not insert fingers, rods, or other objects into the air inlet or outlet. This can cause injury, since the fan may be rotating at high speeds. Internal components can also be damaged.
- Do not use flammable sprays, such as hair spray, lacquer, or paint near the unit. This can cause fire or combustion.
- Do not operate the air conditioner in places near or around combustible gases. Emitted gas may collect around the unit and lead to an explosion.
- Do not operate the air conditioner in a highly humid space (e.g. bathrooms or laundry rooms). This can cause electrical shock and result in early product deterioration.
- Do not directly expose your body to cool air for a prolonged period of time.

ELECTRICAL WARNINGS

- Only power the system through a specified and dedicated circuit breaker. If the power cord is damaged, it must be replaced by a certified service agent.
- Ensure the usage of a properly rated fuse circuit breaker. Gauge of the power wiring must be within the minimum and maximum circuit amperage requirements of this equipment.
- **Do not** pull the power and signal cords. Ensure all wiring used complies with all national electrical codes. System power input must be provided through a hardwired power circuit with proper gauge.
- **Do not** manually extend the power wires, use an extension cord, or connect other appliances to the same breaker with this air conditioner. Poor electrical connections, poor insulation, and high amperage draw can lead to fire.

CLEANING AND MAINTENANCE WARNINGS

- Turn off the device and the breaker before cleaning. Failure to do so can cause electrical shock.
- **Do not** use excessive amounts of water to clean the air conditioner.
- **Do not** clean the air conditioner with combustible cleaning agents. Combustible cleaning agents or other harsh chemicals can result in fire or deformation.



CAUTION

- If the air conditioner is used concurrently with burners or other heating devices, thoroughly ventilate the room in order to avoid oxygen deficiency.
- Turn off the air conditioner and breaker if it will not be in use for an extended period of time.
- Turn off the breaker during lightning or other strong storms.
- Be sure that condensate water can drain out of the unit, unhindered in any way.
- **Do not** operate or touch the air conditioner with wet hands. This can cause electric shock.
- **Do not** use this system for any other purpose than what is intended (indoor environmental comfort).
- **Do not** climb over or place objects on top of the outdoor unit.
- **Do not** allow the air conditioner to operate for long periods of time with doors or windows open, or if the outdoor humidity level is high. Condensate water will accumulate on or near the unit.

Unit Specifications and Features

1

Unit Parts

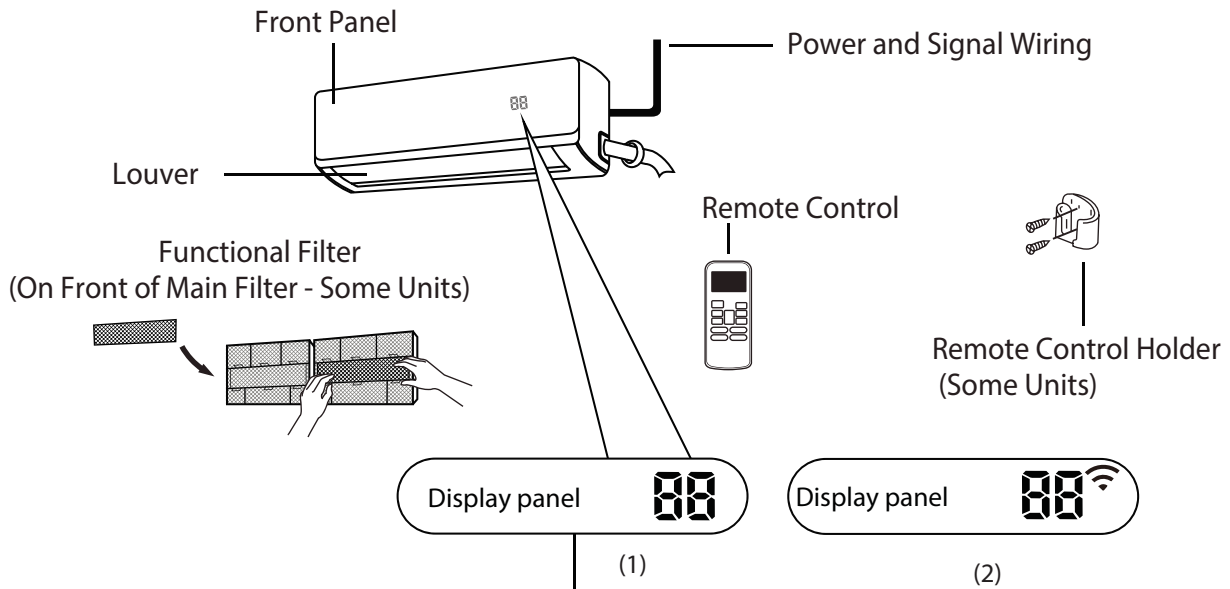

- " **0n** " for 3 seconds when:
- TIMER ON is set
 - FRESH, SWING, TURBO, SILENCE or SOLAR PV ECO features are turned on
- " **0f** " for 3 seconds when:
- TIMER OFF is set
 - FRESH, SWING, TURBO, SILENCE or SOLAR PV ECO features are turned off
- " **cF** " when "Warm Start Delay" feature is activated by the system
- " **dF** " when Automatic Defrosting Mode is activated by the system
- " **Sc** " when unit is self-cleaning
- " **FP** " when Freeze Protection (Low Heat) mode has been turned on
- " **Wi** " when Wireless Control Feature is activated (some units)
- " **88** " When ECO function (optional) is activated, the '88' illuminates gradually one by one as -- E
 [-- 0-set temperature-- E in one second intervals.

Display Code Meanings

In Fan Mode, the unit will display the room temperature.
 In other modes, the unit will display your temperature setting.

NOTE: A guide on using the infrared remote is not included in this literature package. See the additional material provided that corresponds with the included specific remote controller.

Achieving Optimal Performance

Optimal performance for the COOL, HEAT, and DRY modes can be achieved in the following temperature ranges. When your air conditioner is used outside of these ranges, certain safety protection features will activate and cause the unit to perform less than optimally.

Operational Temperature Ranges

Standard Models

	COOL mode	HEAT mode	DRY mode
Room Temperature	17°C - 32°C (63°F - 90°F)	0°C - 30°C (32°F - 86°F)	10°C - 32°C (50°F - 90°F)
Outdoor Temperature	0°C - 50°C (32°F - 122°F)	-15°C - 30°C (5°F - 86°F)	0°C - 50°C (32°F - 122°F)

FOR OUTDOOR UNITS WITH ELECTRIC HEATERS (MOST ARCTIC VERSIONS)

When the outdoor temperature is below 0°C (32°F), we strongly recommend keeping the unit energized at all times to ensure smooth and uninterrupted performance.

Arctic (Low Ambient Temp.) Models

	COOL mode	HEAT mode	DRY mode
Room Temperature	17°C - 32°C (63°F - 90°F)	0°C - 30°C (32°F - 86°F)	10°C - 32°C (50°F - 90°F)
Outdoor Temperature	-15°C - 50°C (5°F - 122°F)	-20°C - 30°C (-5°F - 86°F)	0°C - 50°C (32°F - 122°F)

Full system-rated capacity and efficiency is obtained with the standard rating conditions as developed by the testing and rating agencies. Deviations from rating conditions, especially atmospheric conditions, will be compensated by the variable speed compressor, within certain limitations. Heat pump systems function by exchanging energy, in the form of heat, between the indoor air and the outdoor ambient air (atmospheric). The system's net cooling or heating capacities and efficiencies change with atmospheric conditions, as well as indoor air conditions (such as temperatures and humidity levels).

Capacity of the system required for a specific area or application must be determined professionally using detailed calculations, which are based on several internal and external factors.

To further optimize the performance of your unit, do the following:

- Keep doors and windows closed.
- Limit energy usage by using TIMER ON and TIMER OFF functions.
- Do not block air inlets or outlets.
- Regularly inspect and clean air filters.

For a detailed explanation of each function, refer to the Remote Control Manual.

Other Features

- **Auto-Restart**
If the unit loses power, it will automatically restart with the prior settings once power has been restored (can be overridden by user).
- **Anti-Mildew (some units)**
When switching off the unit from COOL, AUTO (COOL), or DRY modes, the air conditioner will continue to operate at very low power to dry up condensate water, and prevent mildew growth.
- **Wi-Fi Access (Optional Accessory Needed)**
Wi-Fi control allows you to access your air conditioner using your smart phone with a Wireless connection.
For USB device access, replacement, maintenance operations, refer to the manuals provided separately.
- **Louver Angle Memory (some units)**
When turning on your unit, the louver will automatically resume from its previous angle.
- **Refrigerant Leakage Detection (some units)**
The indoor unit will automatically display "EC" when it detects refrigerant leakage.

For a detailed explanation of your unit's advanced functionalities (such as TURBO mode and its self-cleaning functions), refer to the Remote Control Manual.

NOTE ON ILLUSTRATIONS

Illustrations in this manual are for explanatory purposes. The actual shape of your indoor unit may be slightly different. The actual shape shall take precedence over graphical representations.

NOTE ON WI-FI WORLDWIDE REMOTE ACCESS CAPABILITIES



This system is equipped with special electronics for integration with the proprietary Wi-Fi Remote Monitoring and Control Device (Sold Separately). When installed, the Wi-Fi access device adds the following capabilities:

- Remote monitoring of room temperature and humidity conditions.
- Remote control of all available functions of the system.
- Programming options for automatic operation (Weekly-Daily).
- Voice Control integration.
- Home Automation functions.

Wi-Fi integration modules can be easily added to this unit by the owner anytime after purchase. To purchase this optional device, simply contact your dealer or installer.

A smartphone with a working Wi-Fi connection and a free downloadable application are required for the proper function of the Wi-Fi control.

• Setting Angle of Air Flow

Setting Vertical Angle of Air Flow

While the unit is on, use the SWING/DIRECT button to set the direction (vertical angle) of airflow (Dual function button: Left/Right).

1. Press the SWING/DIRECT button once to activate the louver. Each time you press the button, it will adjust the louver by 6°. Press the button until the direction you desire is reached (left side of button).
2. To set the louver to swing up and down continuously, press and hold the SWING/DIRECT button for 3 seconds. Press it again to stop the automatic function.

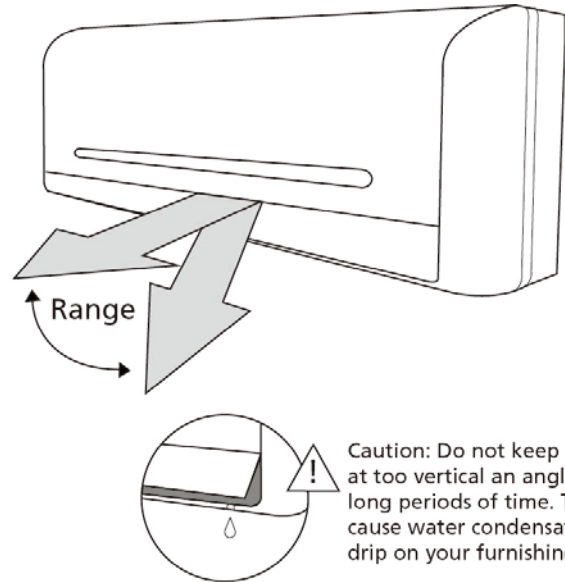

Caution: Do not keep louver at too vertical an angle for long periods of time. This can cause water condensation to drip on your furnishings.

Fig. A

Setting Horizontal Angle of Air Flow

The horizontal angle of the airflow must be set manually. Locate the deflector rod (See Fig.B) and manually adjust it to your preferred direction. For some units, the horizontal angle of the airflow can be set by remote control. Please refer to the Remote Control Manual.

NOTE ON LOUVER ANGLES

When using COOL or DRY mode, do not set the louver at a high vertical angle for extended periods of time. This can cause water to condense onto the louver blade, which will drop to your floor or onto furnishings. (See Fig. A)

When using COOL or HEAT mode, setting the louver at a high vertical angle can reduce the performance of the unit, due to restricted air flow.

Do not move louver by hand. This will cause the louver to go out of sync. If this occurs, turn off the unit and the breaker for a few seconds, then restart the unit. This will reset the louver.

! CAUTION

Do not put your fingers in or near the blower and suction side of the unit. The high-speed fan inside the unit may cause injury.

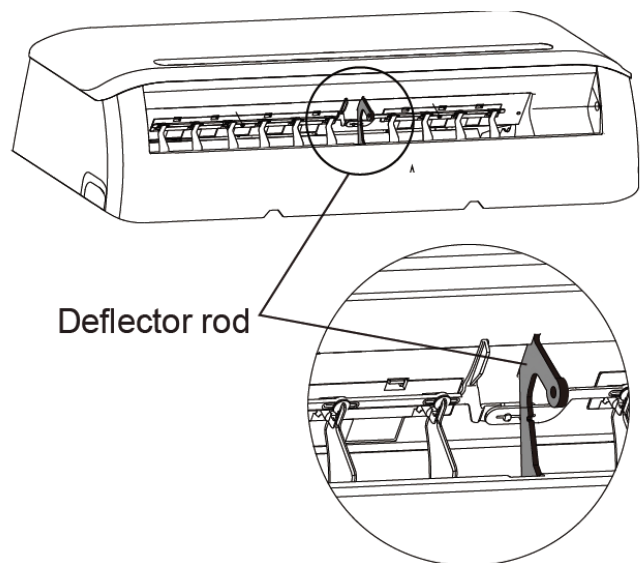

Deflector rod

Fig. B

- Sleep Operation

The SLEEP function is used to decrease energy use while you sleep (and will not require the same temperature settings to stay comfortable). This function can only be activated via remote control.

Press the SLEEP button when you are ready to go to sleep. When in COOL mode, the unit will increase the temperature by 1°C (2°F) after 1 hour, and will increase an additional 1°C (2°F) after another hour. When in HEAT mode, the unit will decrease the temperature by 1°C (2°F) after 1 hour, and will decrease an additional 1°C (2°F) after another hour.

The unit will hold the new temperature for 5 hours, before turning off automatically.

Note: The SLEEP function is not available in FAN or DRY modes.

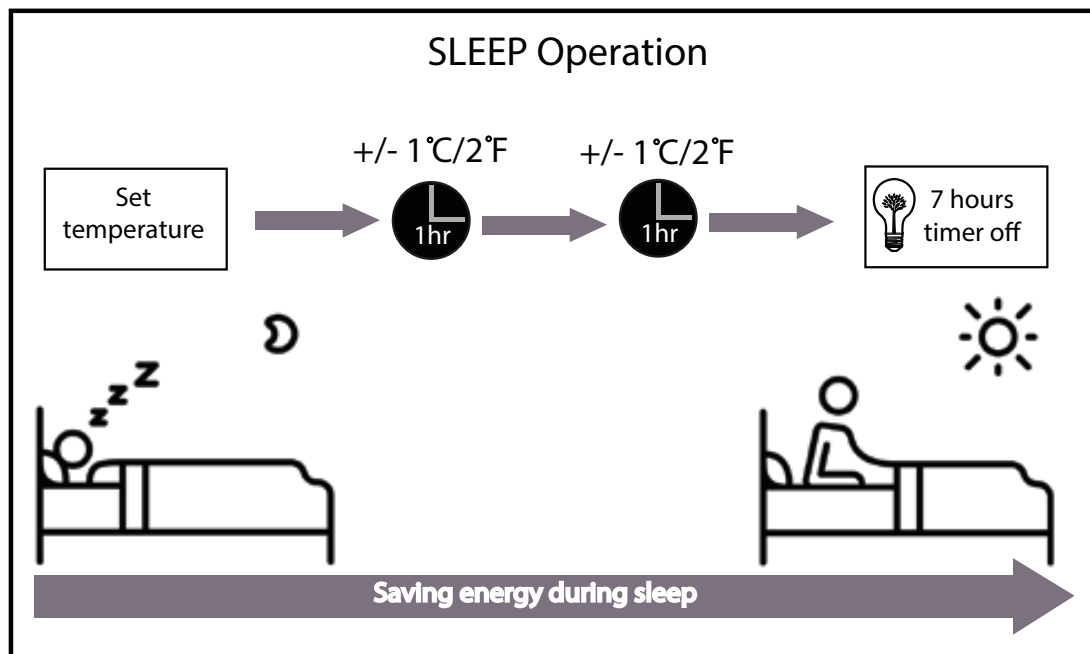

Manual Operation (Without Remote)

2

Operating the Unit without the Remote Control (Using the Emergency Button)

In the event that your remote control fails to work, your unit can be operated manually with the **MANUAL CONTROL** button located on the indoor unit. Note that manual operation is not a long-term solution, and that operating the unit normally using your remote control is strongly recommended, except for emergencies.

BEFORE MANUAL OPERATION

Unit must be turned off before manual operation.

To operate your unit manually:

1. Open the front panel of the indoor unit.
2. Locate the **MANUAL CONTROL** button on the right-hand side of the unit.
3. Press the **MANUAL CONTROL** button one time to activate **FORCED AUTO** mode.
4. Press the **MANUAL CONTROL** button again to activate **FORCED COOLING** mode.
5. Press the **MANUAL CONTROL** button a third time to turn the unit off.
6. Close the front panel.

! CAUTION

The manual button is intended for testing purposes and emergency operation only. Please do not use this function unless the remote is lost and it is absolutely necessary. To restore regular operation, use the remote control to activate the unit.

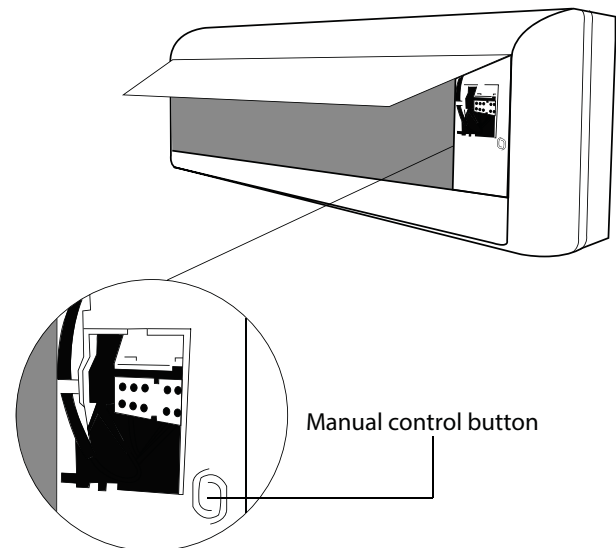

Care and Maintenance

3

Cleaning Your Indoor Unit



BEFORE CLEANING OR MAINTENANCE

ALWAYS TURN OFF YOUR AIR CONDITIONER SYSTEM AND DISCONNECT ITS POWER SUPPLY BEFORE PERFORMING CLEANING OR MAINTENANCE.



CAUTION

Only use soft, dry cloths to wipe the unit clean. If the unit is especially dirty, you can use a cloth soaked in warm water to wipe it clean.

- Do not use chemicals or chemically treated fibers to clean the unit
- Do not use benzene, paint thinner, polishing powder, or other solvents to clean the unit. They can cause the plastic surface to crack or deform.
- Do not use water hotter than 40°C (104°F) to clean the front panel. This can cause the panel to deform, or become discolored.

Cleaning Your Air Filter

A clogged air conditioner can reduce the cooling efficiency of your unit, and can also be bad for your health. Make sure to clean the filter once every two weeks.

1. Lift off the front panel of the indoor unit.
2. Grip the tab on the end of the filter, lift it up, and pull it towards yourself.
3. Pull out the filter.
4. If your filter has a smaller air freshening filter, unclip it from the larger filter. Clean this air freshening filter with a hand-held vacuum.
5. Clean the large air filter with warm, soapy water. Be sure to use a mild detergent.

6. Rinse the filter with fresh water, then shake off the excess water.
7. Store in a cool, dry place and refrain from exposing it to direct sunlight.
8. When dry, re-clip the air freshening filter to the larger filter, then slide it back into the indoor unit.
9. Close the front panel of the indoor unit.

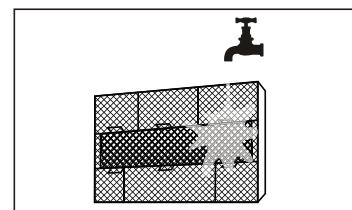
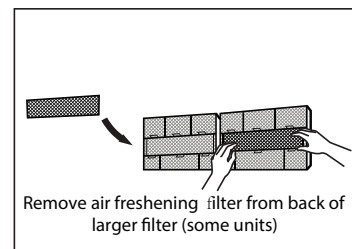
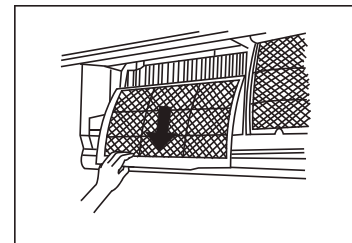
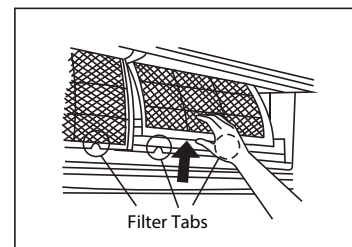

CAUTION

Do not touch air freshening (Plasma) filter for at least 10 minutes after turning off the unit.

! CAUTION

- Before changing or cleaning the filter, turn off the unit and disconnect its power supply.
- When removing filter, do not touch the metal parts in the unit. The sharp metal edges can cause cuts.
- Do not use water to clean the inside of the indoor unit. This can damage the insulation and cause electrical shock.
- Do not expose filters to direct sunlight when drying. This can shrink or deform the filter.

Air Filter Reminders (Optional)

Air Filter Cleaning Reminder

After 240 hours of use, the display panel on the indoor unit will flash "CL." This is a reminder to clean your filter. After 15 seconds, the unit will revert to its previous display.

To reset the reminder, press the LED button on your remote control 4 times, or press the MANUAL CONTROL button 3 times. If you do not reset the reminder, the "CL" indicator will flash again when you restart the unit.

Air Filter Replacement Reminder

After 2,880 hours of use, the display panel on the indoor unit will flash "nF." This is a reminder to replace your filter. After 15 seconds, the unit will revert to its previous display.

To reset the reminder, press the LED button on your remote control 4 times, or press the MANUAL CONTROL button 3 times. If you do not reset the reminder, the "nF" indicator will flash again after restarting the unit.

! CAUTION

- Any maintenance and cleaning of outdoor unit should be performed by an authorized dealer or licensed service provider.
- Any unit repairs should be performed by authorized dealer or licensed service provider.

Maintenance – Long Periods of Non-Use

If you plan not to use your air conditioner for an extended period of time, do the following:

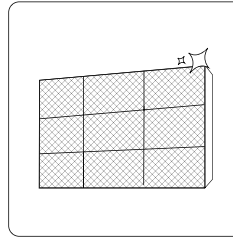

Clean all filters

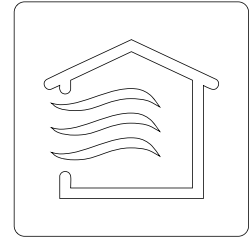

Turn on FAN function until unit dries out completely

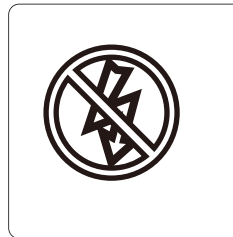

Turn off the unit and the power breaker

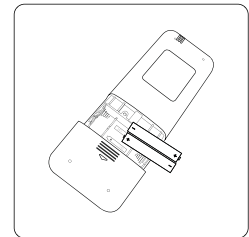

Remove batteries from the remote control

Maintenance – Pre-Season Inspection

After long periods of non-use, or before periods of frequent use, do the following:

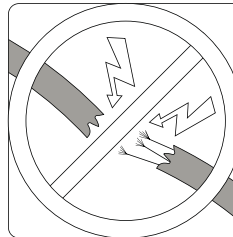

Check for damaged wires

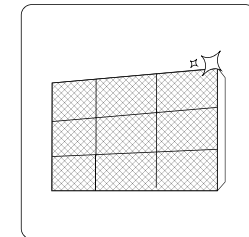

Clean all filters



Check for leaks

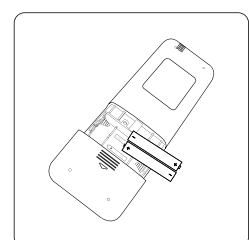

Replace batteries

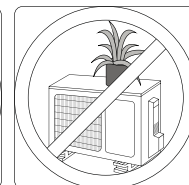
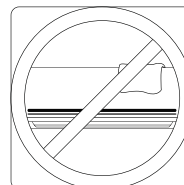

Make sure nothing is blocking any air inlets and outlets

SAFETY PRECAUTIONS

If ANY of the following conditions occur, turn off your unit immediately!

- The power wiring is damaged or abnormally warm
- You notice a burning odor
- The unit emits loud or abnormal sounds
- A power fuse blows or the circuit breaker frequently trips
- Water or other objects fall into or out from the unit

DO NOT ATTEMPT TO FIX THESE CONCERNS YOURSELF! CONTACT AUTHORIZED SERVICE PROVIDER IMMEDIATELY!

Common Issues

The following problems are not malfunctions and in most situations will not require repairs.

Issue	Possible Causes
Unit does not turn on when pressing ON/OFF button	The unit has a 3-minute protection feature that prevents the unit from overloading. The unit cannot be restarted within three minutes of being turned off.
The unit changes from COOL/HEAT mode to FAN mode	The unit may change its setting to prevent frost from forming on the unit. Once the temperature increases, the unit will start operating in the previously selected mode again.
	The set temperature has been reached, at which point the unit turns off the compressor. The unit will continue operating when the temperature fluctuates again.
The indoor unit emits white mist	In humid regions, a large temperature difference between the room's air and the conditioned air can cause white mist to form.
Both the indoor and outdoor units emit white mist	When the unit restarts in HEAT mode after defrosting, white mist may be emitted due to moisture generated from the defrosting process.

Issue	Possible Causes
The indoor unit emits noises	A rushing air sound may occur when the louver resets its position.
	A squeaking sound may occur after running the unit in HEAT mode due to expansion and contraction of the unit's plastic parts.
Both the indoor unit and outdoor unit make noises	Low hissing sound during operation: This is normal and is caused by refrigerant gas flowing through both the indoor and outdoor units.
	Low hissing sound when the system starts, has just stopped running, or is defrosting: This noise is normal and is caused by the refrigerant gas stopping or changing direction.
	Squeaking sound: Normal expansion and contraction of plastic and metal parts caused by temperature changes during operation can cause squeaking noises.
The outdoor unit makes noises	The unit will operate at different sound levels based on its current operating mode and loading.
Dust is emitted from either the indoor or outdoor unit	The unit may accumulate dust during extended periods of non-use, which will be emitted when the unit is turned on. This can be mitigated by covering the unit during long periods of inactivity.
The unit emits a bad odor	The unit may absorb odors from the environment (such as furniture, cooking, cigarettes, etc.) which will be emitted during operation. Heat exchangers may need to be cleaned.
	The unit's filters have become moldy and should be cleaned.
The fan of the outdoor unit does not operate	During the defrost mode, the outdoor fan will be stopped. Otherwise, check for ice or other debris blocking the fan.
Operation is erratic, unpredictable, or the unit is unresponsive	<p>Interference from cell phone towers and remote boosters may cause the unit to malfunction.</p> <p>In this case, try the following:</p> <ul style="list-style-type: none"> • Disconnect the power, and reconnect by resetting the breaker. • Press ON/OFF button on remote control to restart operation.

NOTE: If problem persists, contact your installer or your nearest customer service center. Provide them with a detailed description of the unit malfunction, as well as your model number. Running the system after realizing a serious performance issue or observing an error code may cause further and/or irreversible damage to internal components and loss of the applicable product warranty.

Troubleshooting

When these issues occur, please check the following points before contacting a repair company.

Problem	Possible Causes	Solution
Poor cooling performance	Temperature setting may be higher than ambient room temperature	Lower the temperature setting
	The heat exchanger on the indoor or outdoor unit is dirty	Clean the affected heat exchanger
	The air filter is dirty	Remove the filter and clean it according to instructions
	The air inlet or outlet of either unit is blocked	Turn the unit off, remove the obstruction, and turn it back on
	Doors and windows are open	Make sure that all doors and windows are closed while operating the unit
	Excessive heat is generated by sunlight	Close windows and curtains during periods of high heat or bright sunshine
	Too many sources of heat in the room (people, computers, electronics, etc.)	Reduce amount of heat sources
	Low refrigerant due to leak or long-term use	Check for leaks, re-seal if necessary, and top off refrigerant
SILENCE function is activated (optional function)	SILENCE function can lower product performance by reducing operating frequency. Turn off SILENCE function.	

Problem	Possible Causes	Solution
The unit is not working	Power failure	Wait for power to be restored
	The power is turned off	Turn on the power
	The fuse is burned out	Replace the fuse
	Remote control batteries are dead	Replace batteries
	The unit's 3-minute protection has been activated	Wait three minutes after restarting the unit
	Timer is activated	Turn timer off
The unit starts and stops frequently	Too much or too little refrigerant in the system	Check for leaks and recharge the system with refrigerant.
	Incompressible gas or moisture has entered the system.	Evacuate and recharge the system with refrigerant
	The compressor is broken	Replace the compressor
	The voltage is too high or too low	Install a voltage regulator, or call your local power company
Poor heating performance	The outdoor temperature is extremely low	Keep and use a separate auxiliary heating device when needed
	Cold air is entering through doors and windows	Make sure that all doors and windows are closed and well-sealed during use
	Low refrigerant due to leak or long-term use	Check for leaks, re-seal if necessary, and top off refrigerant
Indicator lamps continue flashing	<p>The unit may stop operation or continue to run safely. If the indicator lamps continue to flash or error codes appear, wait about 10 minutes. The problem may resolve itself.</p> <p>If not, disconnect the power, then connect it again. Turn the unit on.</p> <p>If the problem persists, disconnect the power and contact your installer, dealer, or the nearest customer service center.</p>	
<p>Error code appears in the window display of indoor unit:</p> <ul style="list-style-type: none"> • E0, E1, E2... • P1, P2, P3... • F1, F2, F3... 		

NOTE: If your problem persists after performing the checks and diagnostics above, turn off your unit immediately and contact your installer, dealer, or the service center. Running the system after realizing a serious performance issue or observing an error code may cause further and/or irreversible damage to internal components and loss of the applicable product warranty.

This appliance contains refrigerant and other potentially hazardous materials. When disposing of this appliance, the law requires special collection and treatment. Do not dispose of this product as household waste or unsorted municipal waste.

When disposing of this appliance, the following options are available:

- Dispose of the appliance at a designated municipal electronic waste collection facility.
- When buying a new appliance, the retailer will take back the old appliance free of charge.
- The manufacturer will take back the old appliance free of charge.
- Sell the appliance to certified scrap metal dealers.

Special Notice

Disposing of this appliance improperly or in other natural surroundings endangers your health and is bad for the environment. Hazardous substances may leak into the ground water and enter the food chain.

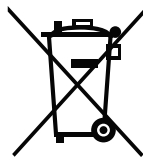

Indoor Unit Error Codes List

Operation lamp	Timer lamp	Display	LED STATUS
☆ 1 time	X	E0	Indoor unit EEPROM parameter error
☆ 2 times	X	E1	Indoor / outdoor units communication error
☆ 3 times	X	E2	Zero-crossing signal detection error
☆ 4 times	X	E3	Indoor fan speed has been out of control
☆ 5 times	X	E4	Indoor room temperature sensor T1 open circuit or short circuit
☆ 6 times	X	E5	Evaporator coil temperature sensor T2 open circuit or short circuit
☆ 7 times	X	EC	Refrigerant leakage detection
☆ 1 times	O	F0	Overload current protection
☆ 2 times	O	F1	Outdoor ambient temperature sensor T4 open circuit or short circuit
☆ 3 times	O	F2	Condenser coil temperature sensor T3 open circuit or short circuit
☆ 4 times	O	F3	Compressor discharge temperature sensor TP open circuit or short circuit
☆ 5 times	O	F4	Outdoor unit EEPROM parameter error
☆ 6 times	O	F5	Outdoor fan speed has been out of control
☆ 1 times	☆	P0	IPM malfunction or IGBT over-strong current protection
☆ 2 times	☆	P1	Over voltage or over low voltage protection
☆ 3 times	☆	P2	High temperature protection of IPM module or compressor shell top
☆ 4 times	☆	P3*	Outdoor ambient temperature too low.
☆ 5 times	☆	P4	Inverter compressor drive error
☆ 6 times	☆	P5	Indoor units mode conflict (multi-zone ONLY)
☆ 7 times	☆	P6	Low pressure protection(Only for 36K)

O (light) X (off) ☆ (flash)

*P3

1) In heating mode, when the outdoor temperature is lower than -25°C (-13F) for 1 hour, the indoor unit display error code P3. Low Ambient Protection.

2) If the outdoor temperature goes higher than -22°C (-8F) for 10 minutes and compressor has stopped for 1 hour or outdoor temperature goes higher than -5°C (23F) for 10 minutes, then the unit will restart.

* **Fault Symptom:** The display board shows a garbled code or a code that is not an error code found in the service manual nor a temperature reading.

A more comprehensive service and diagnostics manual is available for the service technicians. Contact the manufacturer for the download instructions.

The design and specifications are subject to change without prior notice for product improvement. Consult with the sales agency or manufacturer for details.

Refer to the equipment nameplate for all other applicable specifications.



is a registered trademark of Parker Davis HVAC International, Inc.

Parker Davis HVAC International, Inc.

2250 NW 102 Place, Doral, FL 33172 - USA

Tel : (305) 513-4488

Fax : (305) 513-4499

email : info@pd-hvac.com

Website: www.pd-hvac.com

CS368U-AB
16122000002334
20171221